



MANUAL CHARCOAL **PARRILLA** 642

EXAMPLE PHOTO SIDE:
TWO SIDE LIFTER GRILLS

FEATURES | BENEFITS

CUSTOMIZED CONSTRUCTION

- This equipment can be customized according to the customer needs from 800 / 31 1/2 up to 2500 / 98 7/16.

FIRE LIGHTER

- PRE BURN CHARCOAL AND WOOD just spread it along the fire pit.

LIFT GRILL SYSTEM

- Grilling area is equipped with manual up/down lifting grill system.

HYGIENE

- Equipment coated in brushed stainless steel AISI 304 or AISI 430 (please specify when ordering).

HIGH QUALITY

- Equipment designed and built to high standards to provide the best results.

SIMPLE TO USE

- Equipment easy and simple to use.

MACHINE STRUCTURE

- Internal tube structure carbon steel;
- 5" casters which helps the displacement for maintenance and cleaning;
- Carbon steel tank SAE 1020 cover with refractory bricks;
- High grade heat insulation under refractory bricks in fire pit saves 20-30% charcoal usage;
- Easy way to remove and maintain the refractory bricks with "T" bar system;
- Two years parts and labor warranty from date of purchase.

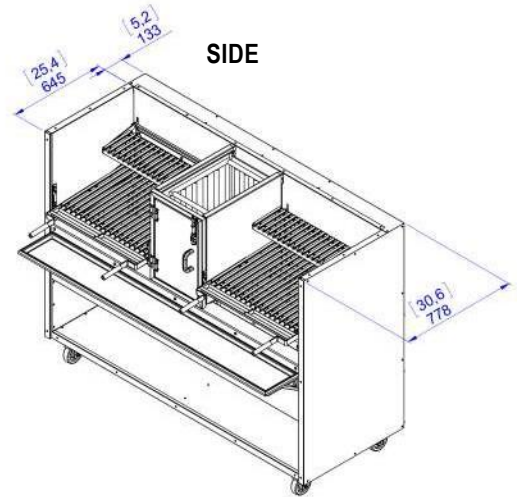
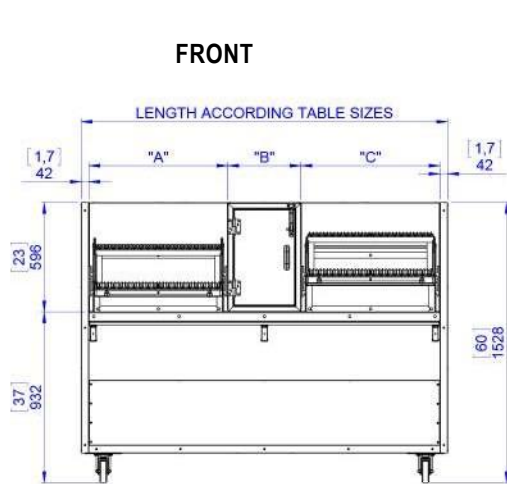

*Back clearance 100mm / 4 inches

TABLE SIZES

"A" - PARRILLA** OVERALL LENGTH	"B" - FIRE LIGHTER OVERALL LENGTH	COOKING AREA / LENGTH	DEPTH
800 / 31 3/8	400 / 15 3/4	685 / 26,96"	553 / 21,77"
1000 / 39 3/8	500 / 19 11/16	885 / 34,84"	553 / 21,77"
1200 / 47 1/4	600 / 23 5/8	1085 / 42,71"	553 / 21,77"
1500 / 59 1/16	700 / 27 9/16	1385 / 54,52"	553 / 21,77"
1800 / 70 7/8		1685 / 66,33"	553 / 21,77"
2000 / 78 3/4		1885 / 74,21"	553 / 21,77"
2200 / 86 5/8		2085 / 82,08"	553 / 21,77"
2500 / 98 7/16		2385 / 93,89"	553 / 21,77"

*Dimensions in milimetres / inches;

**For special size consult our staff;

***Grill section maximum length 1000mm / 39 3/8; when over this size unit will have two section or more.

HOOD

Ventilation calculations need to be confirmed by a local specialist mechanical ventilation consultant or contractor to make sure the system meets local codes.

For USA only:

MAX COOKING SURFACE TEMP °F	MINIMUM EXHAUST AIRFLOW (CFM/FT)*
400	275
600	275
700	300+

*Exhaust airflow is capable of being as low as listed above. Since charcoal will be giving off grease laden smoke, it is important to capture all the smoke by providing a larger amount of CFM for the capture of the smoke produced by these solid fuel appliances.

MAX COOKING SURFACE TEMP °F	LENGHT (FT)**	WIDTH (IN)***
400	3 min / 16 max	39 min / 72 max
600	3 min / 16 max	39 min / 72 max
700	5 min / 16 max	39 min / 72 max

Note:

1. There needs to be a 6" overhang on either side of the appliance being used for correct sizing of the hood system. Ex: char broiler is 36". Hood length needs to be 42".

2. Charcoal (solid fuel) appliances need to be hooded separate from any other appliances. Cannot mix gas and solid fuel appliances under same hood.

Exception, if the hood is up against a sidewall, disregard 6" overhang where hood is on sidewall.

UTILITY INFORMATION

MISCELLANEOUS

- Check local codes for fire and sanitary regulations, manufacturer is not responsible for installation.

OPTIONAL ITEMS

- Front counter to help chef's operation (foldable or not) and it can come with opening for GN tray;
- Ash collector drawer;
- Charcoal storage compartment;
- Front bar 4.75mm (stronger);
- Manual or automatic up/down grilling system.